

## TCAM2500 VISUAL PLUS THERMAL MONITORING SYSTEM

### FEATURES

- Dual visual plus thermal monitoring in a single camera
- Engineered for operation in Electric Power substations
- Automated temperature monitoring of critical assets
- Monitor multiple temperature points /assets
- Notification through SCADA or email
- Storage of temperature readings in system database

### KEY BENEFITS

- Thermal temperature readings with visual confirmation
- Reliable operation in harsh environments with high levels of EMI, ESD, voltage surges and interrupts
- More reliable continuous temperature readings under all system load conditions
- Reduced downtime due to unplanned outages by detection of potential problems before failures occur
- Reduced monitoring requirements for operations personnel
- Temperature trending analysis allows input into condition based maintenance program

The risk of outages is increasing on the electric power grid due to its aging infrastructure and lack of automation systems that monitor the condition of critical equipment at substations and along the grid. Transformer fluid leaks or insulation breakdown cause overheating that is a warning of potential failures, but many utilities don't have automated thermal detection systems that can help reveal these problems.

Continuous thermal monitoring systems are able to anticipate, detect, and respond rapidly to problems, thereby reducing the chance of failures, outages and lost productivity. Detection of temperature increases in substation equipment with thermal monitoring cameras allows preventative maintenance operations before an unplanned outage occurs due to asset failure.

The Systems With Intelligence thermal monitoring solution includes a substation hardened digital video server (DVS) that digitally records video from multiple cameras and incorporates a suite of sophisticated video and thermal analytic algorithms for detection of anomalies. The DVS includes software tools for video monitoring and analysis, features flexible networking capabilities and provides automated alarm and event notification.

# SUBSTATION MONITORING ARCHITECTURE

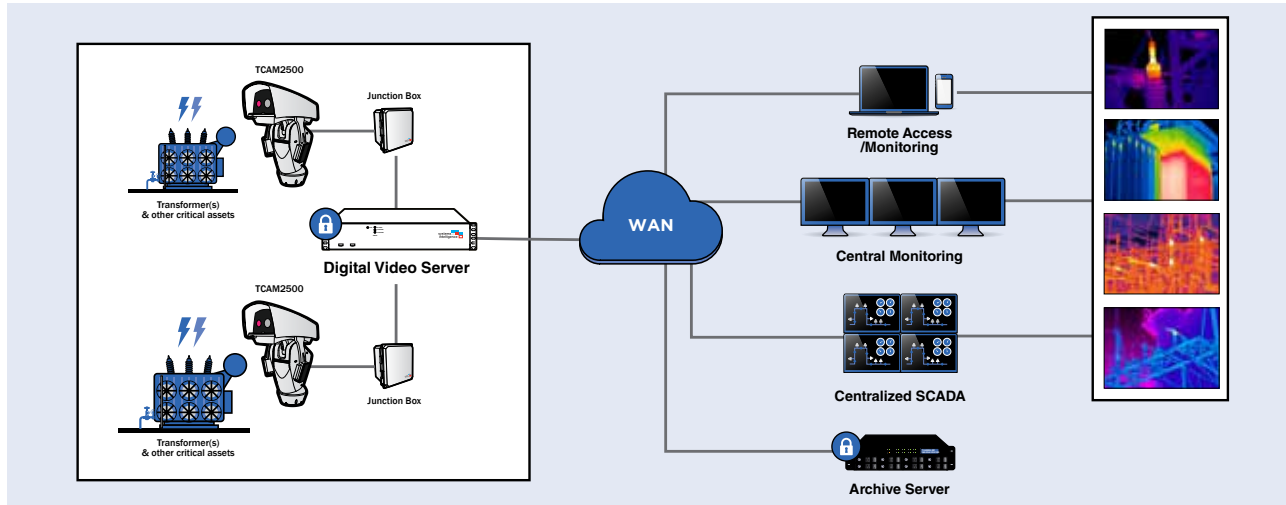

## APPLICATIONS

The Systems With Intelligence thermal monitoring solution can be used to monitor and analyze the thermal signatures of the following substation components. Abnormal thermal signatures are precursors to potential equipment failures.

- Power transformers (oil levels, radiators and pump operation)
- Load tap changers
- Insulator bushings
- Standoff insulators
- Lightning arrestors
- Circuit breakers
- Mechanical disconnects
- Control cabinets
- Batteries

## TECHNICAL SPECIFICATIONS

SPECIFICATIONS	
IMAGING PERFORMANCE	
Field of View, focal length	TL01/TS01= 25° x 19°, 13mm, 336 x 256 pixels TL02/TS02= 45° x 35°, 7.5mm, 336 x 256 pixels TL03/TS03= 35° x 27°, 9mm, 336 x 256 pixels TL04/TS04= 17° x 13°, 19mm, 336 x 256 pixels TL05/TS05= 13° x 10°, 25mm, 336 x 256 pixels VL01/VS01= 25° x 20°, 25mm, 640 x 512 pixels VL02/VS02= 45° x 37°, 13mm, 640 x 512 pixels VL03/VS03= 32° x 26°, 19mm, 640 x 512 pixels VL04/VS04= 18° x 14°, 35mm, 640 x 512 pixels VL05/VS05= 12° x 9.9°, 50mm, 640 x 512 pixels
Resolution	336 x 256 or 640 x 512 pixels
Detector Type	Uncooled VOx Microbolometer
Pixel Pitch	17µm
Scene Range (High Gain)	-25 °C to 135 °C
Scene Range (Low Gain)	-40 °C to 550 °C
Time to Image	<4.0secs
Video Compression	H.264

NETWORK	
Interface	Pan/Tilt Housing: 10/100TX, RJ45
Security	Password Protected
Protocols	IPv4/v6, DHCP, HTTP, UDP, RTP/RTSP, UPnP, NTP, ICMP
Software Interface	Web Server
THERMAL	
Spectral band	7.5 to 13.5 µm
Sensitivity	0.1° C
Frame rate	TL/VL0x = 30Hz, TS/VS0x = 7.5Hz
ENVIRONMENTAL WITH PAN/TILT HOUSING	
Operating Temperature Range	-40° to 85° C
Encapsulation	IP66 (IEC 60529)
Wind Resistance	Operational: up to 160km/h Stationary: up to 210 km/h
Resistance to Salty Fog	EN50130-5, EN60068-2-52
Certifications	IEC61850-3, IEEE1613, EN60950-1, EN6095-22, EN61000-6-4, EN55022 Class A, EN50130-4
* The specification for this product may change without prior notice for product improvement.	

## SPECIFICATIONS: DAY/NIGHT CAMERA

CAMERA	
Sensor:	1/2.8" CMOS Progressive Scan (2MP)
Lens:	Compatible with CS Mount or C Mount with adaptor DC Auto Iris Support
Day/Night:	IR cut filter removal (ICR) Off/Dusk/Dark/Custom
Iris:	DC-Auto/Manual
Min. illumination:	0.2 lux @ F1.2 (Colour) 0.01 lux @ F1.2 (BW)
VIDEO	
Video Compression:	H.264 (MPEG-4 Part 10) MJPEG
Resolution:	1920 x 1080 (1080p) 1280 x 720 (720p) 720 x 480 (D1) 704 x 480 (4CIF) 704 x 240 (2CIF) 352 x 240 (CIF) 176 x 120 (QCIF)
Frame Rate:	30 fps for all resolutions (except 1080p & 720p-15fps)
Video Streaming:	Triple Stream: 2ch H.264, 1ch MJPEG Stream-profile: resolution /compression / framerate / video quality
Analog Video Out:	BNC port, NTSC/PAL
Image Setting:	Brightness, Contrast, AWB, Sharpness, Saturation, Gain, White Balance, Auto Exposure
Image Mirroring:	Horizontal/Vertical/Both
* The specification for this product may change without prior notice for product improvement.	

## SPECIFICATIONS: HOUSING

GENERAL	
Built in aluminium and ABS	
Epoxy polyester powder painting, RAL9002 colour	
Top mount (OTT)	
Transmission through toothed belt	
Slip-ring	
Electronic limit switches	
Plug installation thanks to connector and easy replacement on-site	
Zero backlash	
MECHANICAL	
Cable glands: 3xM16	
Horizontal rotation: continuous	
Vertical rotation: from +45° up to -20°	
Horizontal speed (variable): from 0.02°/s up to 20°/s through toothed belt	
Tilt speed (variable): from 0.02°/s up to 20°/s	
COMMUNICATIONS	
Ethernet connection: IEEE 802.3 100Base-Tx	
PROTOCOLS	
Pelco-D	

## ENVIRONMENT

Indoor/Outdoor
Operating temperature (with heater): -40 °C (-40 °F)/+85 °C (185 °F)
Surge immunity: up to 2kV line to line, up to 4kV line to earth (Class 4)

## CERTIFICATIONS

Electrical safety: EN60950-1
Photobiological safety of lamps and lamp systems (LED illuminators): EN62471
Electromagnetic compatibility: , EN55022 (Class A), FCC Part 15 (Class A)
Immunity: EN50130-4
Outdoor installation: EN60950-22
IP protection degree: EN60529 (IP66)
Resistant to salty fog: EN50130-5, EN60068-2-52

## ELECTRICAL

24VAC, 50/60Hz, 160W
* The specification for this product may change without prior notice for product improvement.

# PAN/TILT HOUSING DIMENSIONS Unit: mm

## TCAM2500 with Weights

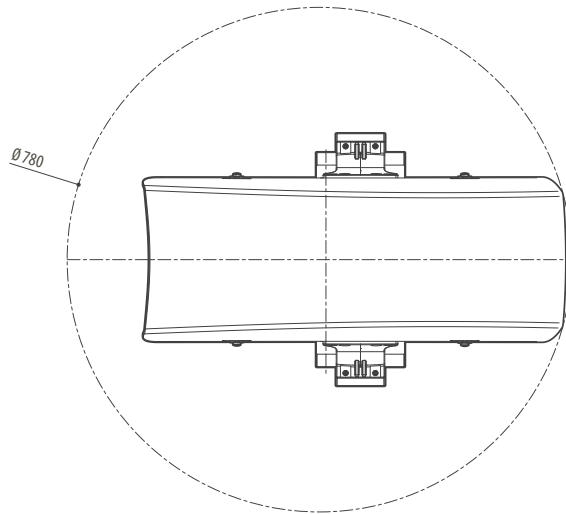
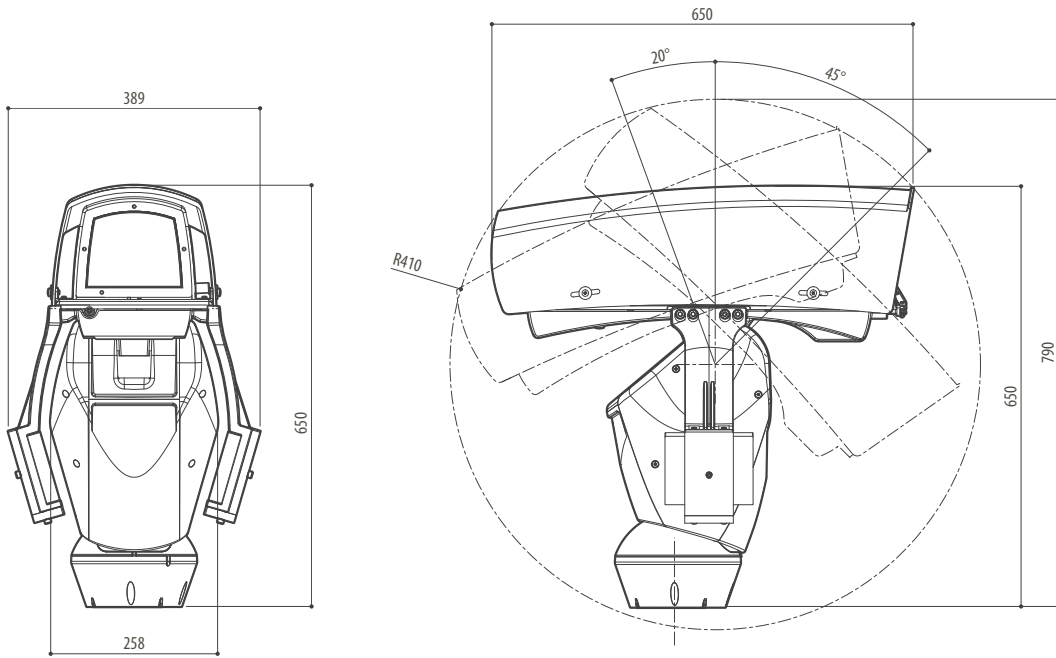

# PAN/TILT HOUSING DIMENSIONS Unit: mm

## TCAM2500 with Illuminators

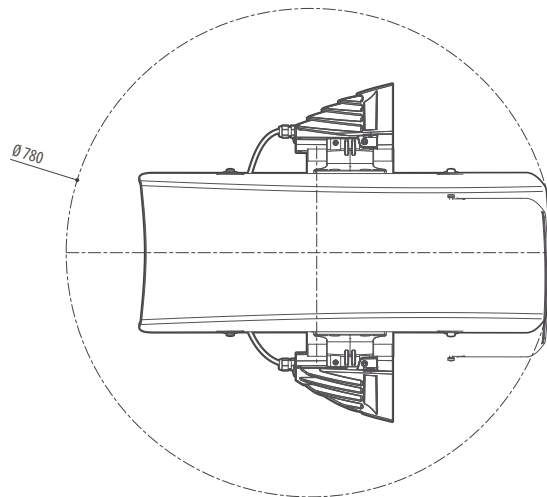
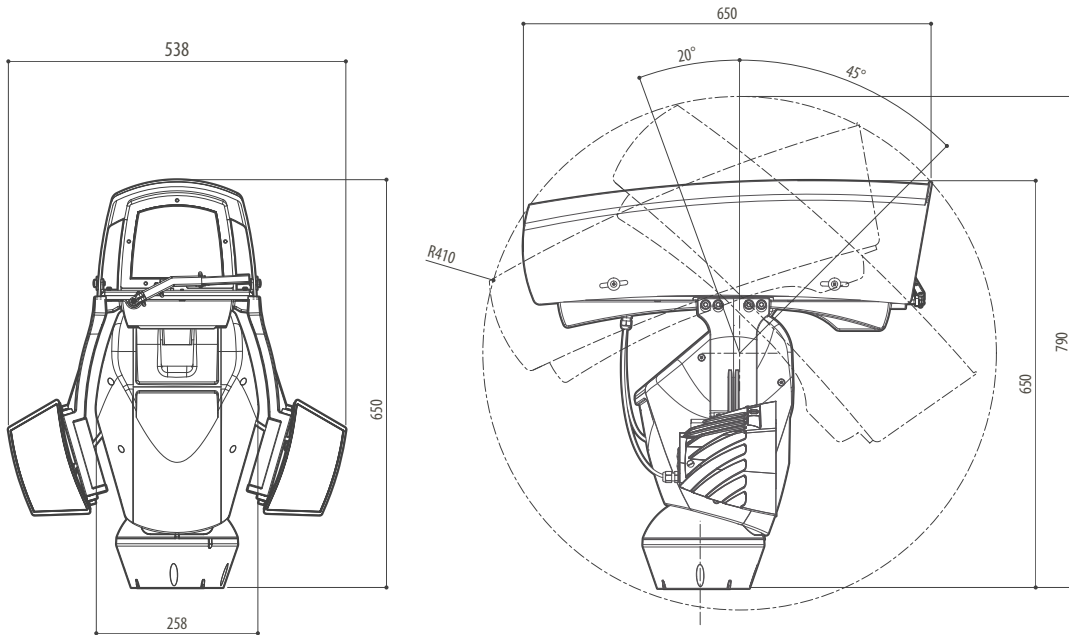

# MOUNTING OPTIONS Unit: mm

## Parapet Bracket, Option A04

- Made of die-cast aluminum
- Epoxypolyester power painting
- Internal cable management
- Unit Weight: 1.6kg (3.5lb)

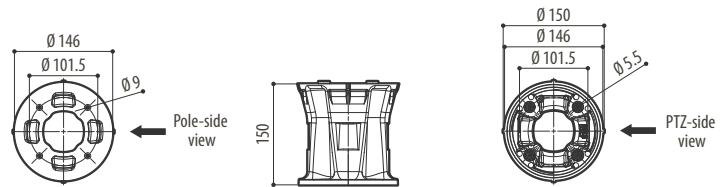

## Wall Mount Bracket, Option A08

- Made of die-cast aluminum
- Epoxypolyester power painting
- Wall bracket with internal cable channel
- Unit Weight: 3.1kg (6.6lb)

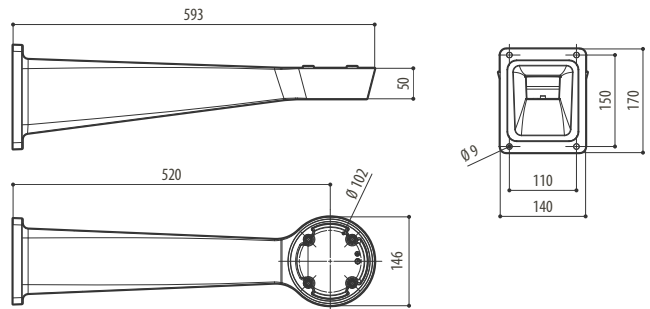
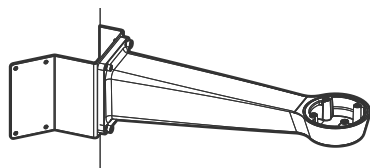

## Pole Mount Bracket with Arm, Option A13

- Pole Installation
- Pole Diameter: 80- 150mm (3.14 - 5.9in)

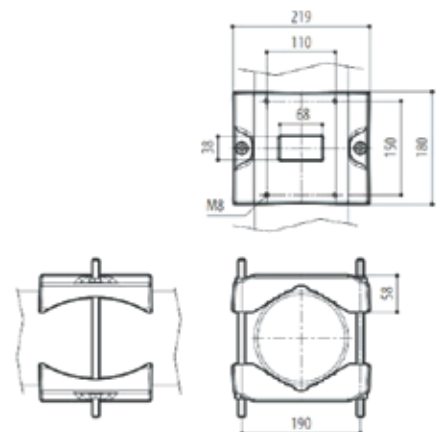
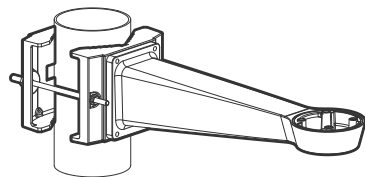

## Accessories

### Illuminator

- Adjustable built-in twilight sensor for automatic activation and deactivation
- Die-cast aluminium body
- Unit weight: 1.5kg (3.3lb)

### Illuminator Power Supply - PS-120IRLED

- 120VAC IRLED Illuminator Power Supply
- Required with PT04 Housing

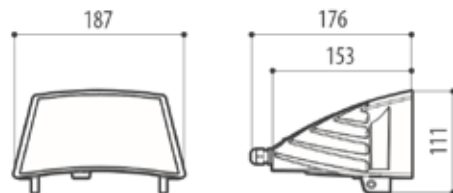

# CONFIGURATION



<b>BASE UNIT</b>		<b>Description</b>
TCAM2500		Thermal Camera System with combined Day/Night and Thermal
<b>HOUSING</b>		
PT03		Pan Tilt Housing - 24VAC
PT04		Pan Tilt Housing - 120VAC
<b>FIELD OF VIEW</b>		
TL01/TS01		25° x 19°, 13mm, 336 x 256 pixels (30Hz/7.5Hz)
TL02/TS02		45° x 35°, 7.5mm, 336 x 256 pixels (30Hz/7.5Hz)
TL03/TS03		35° x 27°, 9mm, 336 x 256 pixels (30Hz/7.5Hz)
TL04/TS04		17° x 13°, 19mm, 336 x 256 pixels (30Hz/7.5Hz)
TL05/TS05		13° x 10°, 25mm, 336 x 256 pixels (30Hz/7.5Hz)
VL01/VS01		25° x 20°, 25mm, 640x512 pixels (30Hz/7.5Hz)
VL02/VS02		45° x 37°, 13mm, 640x512 pixels (30Hz/7.5Hz)
VL03/VS03		32° x 26°, 19mm, 640x512 pixels (30Hz/7.5Hz)
VL04/VS04		18° x 14°, 35mm, 640x512 pixels (30Hz/7.5Hz)
VL05/VS05		12.4° x 9.9°, 50mm, 640x512 pixels (30Hz/7.5Hz)
<b>DAY/NIGHT CAMERA</b>		
FZ02		High Definition 10x Zoom, 5.1 to 51mm lens
FZ06		High Definition 36x Zoom, 6 to 216mm lens
<b>BRACKETS</b>		
A04		Parapet Bracket for Pan/Tilt Housing
A08		Wall Mount Bracket for Pan/Tilt Housing
A13		Pole Mount Bracket for Pan/Tilt Housing
AXX		No Mounting Accessory provided
<b>ILLUMINATORS</b> <i>(only available with PT03 Housing)</i>		
IR108		10 degree, 850nm, LED Illuminator
IR308		30 degree, 850nm, LED Illuminator
IR608		60 degree, 850nm, LED Illuminator

**NOTE:** If illuminators are used with PT04 housing power supply PS-120IRLED is required.



Systems With Intelligence Inc.  
6889 Rexwood Road, Unit #9  
Mississauga, Ontario, CANADA  
L4V 1R2

Tel: +1-289-562-0126  
Fax: +1-289-562-0152

**General Inquiries:**

[info@SystemsWithIntelligence.com](mailto:info@SystemsWithIntelligence.com)

**Sales Inquiries:**

[sales@SystemsWithIntelligence.com](mailto:sales@SystemsWithIntelligence.com)

**Product Support:**

[support@SystemsWithIntelligence.com](mailto:support@SystemsWithIntelligence.com)

All specifications in this document are subject to change without notice.

© Copyright 2022 Systems With Intelligence Incorporated. All rights reserved.

